

Built Well. Built to Last.

Material Master[®] Power-Fill[®] Bulk Bag Fillers



INDUSTRY LEADING PERFORMANCE | EASY OPERATION WITH INTUITIVE CONTROLS | ENHANCED OPERATOR SAFETY

The robust line of Power-Fill[®] Bulk Bag Fillers provide the durability, high performance and reliability to get your dry powders and bulk solids to your customers safely, efficiently and more cost-effectively.

Designed to transform operations, our Power-Fill[®] filling systems deliver unrivaled material handling solutions for a wide array of companies in the food, chemical and pharmaceutical industries. Our filling systems are fully customizable for high-, medium- and low-volume applications.

With your needs front and center, our customization experts have put their decades of experience to work taking costs out of these powerful systems without compromising any of the advantages and quality you count on.



**MATERIAL
TRANSFER**

Inspiring a Better Way

Power-Fill® Bulk Bag Fillers

Power-Fill® Select

AN **EXTREMELY CUSTOMIZABLE** FILLER DESIGNED FOR **MEDIUM-VOLUME** FILLING APPLICATIONS

Standard Equipment Included

- 1. Pneumatic Power-Lift™** For powered fill head height adjustment - *Exclusively on our Power-Fill® Select.*
- 2. Pallet support deck in filler base** Safely supports pallet and bulk bag during filling cycle.
- 3. Fill head with inflatable spout seal** Provides a secure connection to the bulk bag fill spout for dust-free filling.

Power-Fill® Select Common Options

Easy-Load™ Rotary Bag Hanger

The bag hanger rotates around a center axis for reliable reach-free bag loop connection.

Fill By Weight With load cells added to the base of the frame, unit can be configured for gain in weight filling and automation.

Loop-Lok™ Powered Bag Strap Release Safe and secure bag loop support with automatic release.

Allen-Bradley Micro Series PLC/HMI

Reduced labor cost with consistent filling results.

Pneumatic Bag Inflation with Valve

Shapes bag prior to filling for maximum fill volume and stability.

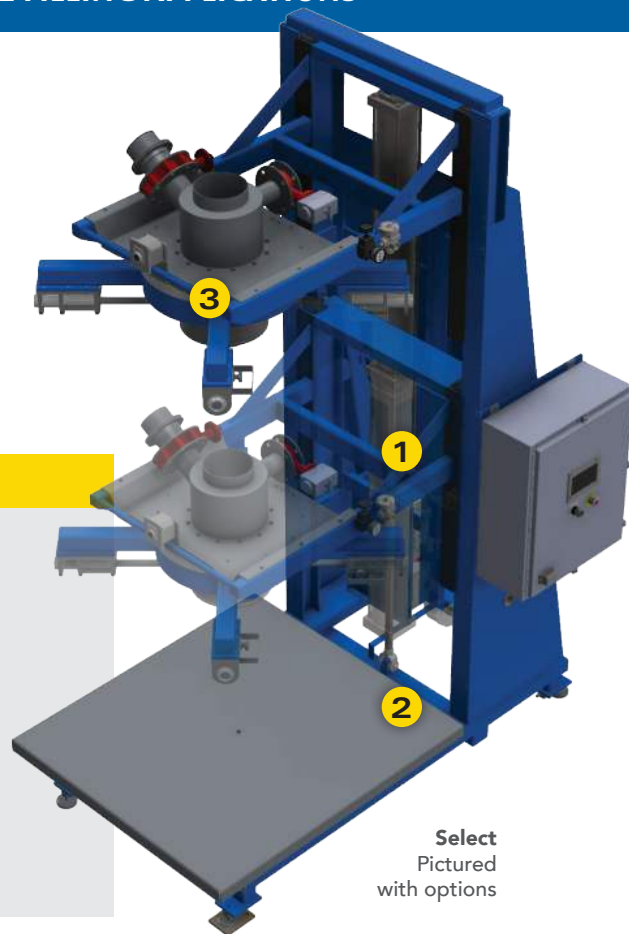

Select
Pictured
with options

Power-Fill® Limited

AN **ECONOMICAL LOW-VOLUME** FILLER WITH A **WIDE RANGE OF OPTIONS**

Standard Equipment Included

- 1. Fill head with inflatable spout seal including a dust vent port**
- 2. Adjustable manual strap hangers for square or rectangular bags**
- 3. Manual frame height adjustment to accept a wide range of bag sizes**

Power-Fill® Limited Common Options

Integrated Platform Scale

Provides gain in weight filling capability.

Digital Weight Display

Programmed for reliable, accurate gain in weight filling.

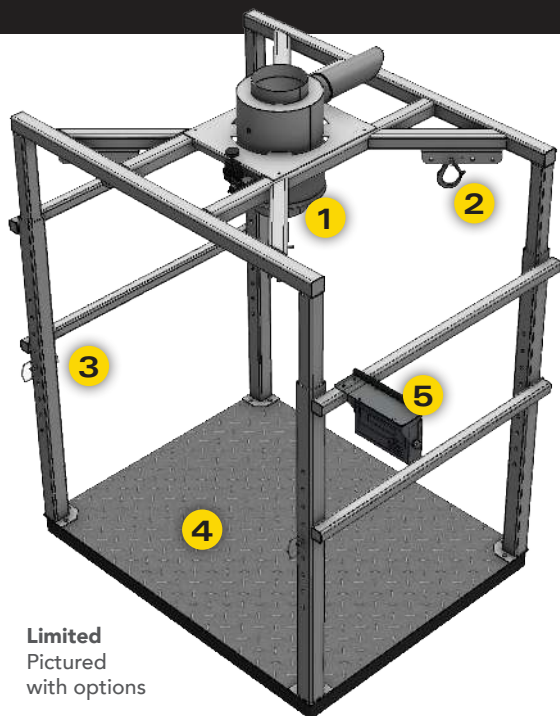

Limited
Pictured
with options

Power-Fill® Pro

A ROBUST, AUTOMATED SYSTEM
FOR HIGH-VOLUME PRODUCTION

Standard Equipment Included

- 1. Easy-Load™ Rotary Bag Hanger** Reach-free bag loop attachment, shrouded for operator safety, reliable and low maintenance.
- 2. Loop-Lok™ Powered Bag Strap Release** Safe and secure bag loop support with automatic release.
- 3. Power-Lift™ Hydraulic Fill Head Adjustment** Powered fill head height adjustment with 48" travel. Ergonomic bag connection, operator and bag size flexibility and bag elongation.
- 4. Compact Logix PLC with 10" color HMI** Reduced labor cost, improved safety and efficiency, and consistent filling results.

Available Exclusively on the PowerFill® Pro

Power-Trak™ Bag Support Carriage

Traversing bag support carriage extends 12" horizontally for reach-free, ergonomic bag spouting.

Hang Weigh Scale

Bag is suspended from an isolated weighing assembly during filling for extremely accurate weighments.

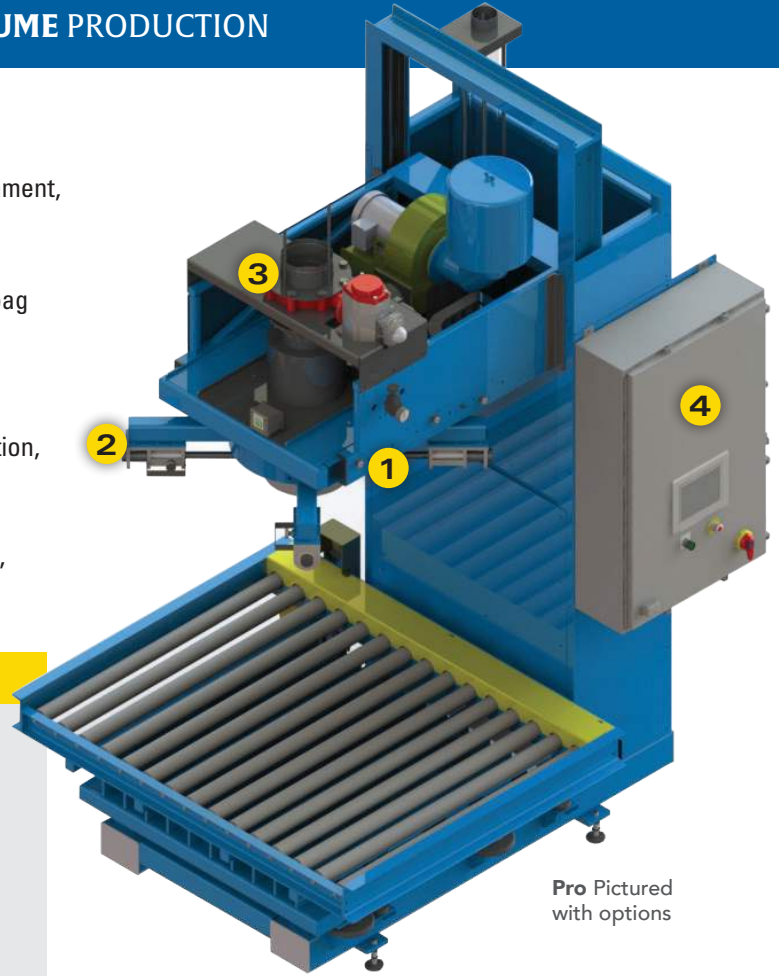

Pro Pictured with options

Maximize the Value of Your System

Whether you turn to us for a single machine, an entire process line or a new system, count on our service and support personnel to help minimize downtime and maximize performance. From front-end support to year-long service contracts to equipment evaluations, we work together to find an optimal solution for your unique needs.

To learn more about the support and service offerings, visit www.materialtransfer.com/services/

Contact our customization experts to learn how we can transform your operations!

OPTIONS & FEATURES

	POWER-FILL® PRO	POWER-FILL® SELECT	POWER-FILL® LIMITED
Bag inflation system, pneumatic or electric	Optional	Optional	Optional
Clean-in-place system	Optional	Optional	Optional
Densification system	Optional	N/A	Optional
Dust take off on fill head with stub, no valve	Optional	Standard	Optional
Dust take off on fill head with actuated valve	Standard	Optional	Optional
Easy-Load™ rotary bag hanger	Standard	Optional	N/A
Fill by volume	Optional	Optional	Optional
Fill by weight, load cells beneath frame	Standard	Optional	Optional
Fill by weigh, hang weigh	Optional	N/A	N/A
Fill head with inflatable spout seal	Standard	Standard	Standard
Gravity roller conveyor in filler base	Optional	Optional	Optional
Inlet isolation valve at filler inlet	Optional	Optional	Optional
Inlet valves or metering devices	Optional	Optional	Optional
Manual bag loop attach/release	N/A	Standard	Standard
PLC (A/B Micro with 7" color HMI)	N/A	Optional	Optional
PLC (A/B Compact Logix with 10" color HMI)	Standard	N/A	N/A
Pallet support deck	Standard	Standard	N/A
Powered bag strap release (Loop-Lok™ system)	Standard	Optional	N/A
Powered filler base conveyor	Optional	Optional	Optional
Power-Lift™ powered height adjustment	Hydraulic	Pneumatic	N/A
Power-Trak™ traversing bag support carriage	Optional	N/A	N/A
Shrouding package	Standard	Standard	N/A
Pallet or slip sheet dispensers	Optional	Optional	Optional

Material Transfer is an industry leader in the custom design and manufacture of bulk bag, container and drum filling, conditioning and discharging systems for dry powders and bulk solids. Building products robust in design, elegant in operation, simple to use and easy to maintain, you can count on Material Transfer for all your material handling needs.



Container Dischargers



Drum Dischargers



Bulk Bag Dischargers



Bulk Bag Conditioners



**MATERIAL
TRANSFER**

MaterialTransfer.com

269-673-2125
sales@materialtransfer.com