

# VERSATILE PERFORMANCE. UNMATCHED ACCURACY.

**Power-Fill® Bulk Bag Fillers**



**Watch Now**

# POWER-FILL® BULK BAG FILLERS

The durable Power-Fill® Bulk Bag Fillers deliver reliable performance for low- to high-volume filling applications, ensuring long-lasting operation and efficiency across various material handling needs.

Our bulk bag and container filling systems integrate seamlessly into your existing bulk material handling equipment, enhancing efficiency and minimizing downtime. Customizable to fit specific powder filling solutions, they ensure accurate and optimized filling for various applications.



## POWER-FILL® PRO

A ROBUST, AUTOMATED SYSTEM FOR HIGH VOLUME PRODUCTION

### STANDARD EQUIPMENT BENEFITS

- 1. Streamlined and Safe Bag Loading:** The Easy-Load™ Rotary Bag Hanger provides reach-free bag loop attachment, ensuring operator safety with its shrouded design.
- 2. Simplify Bag Removal Process:** The Loop-Lok™ Powered Bag Strap Release offers secure bag loop support with automatic release, enhancing operator safety.
- 3. Flexible and Ergonomic Bag Filling** The Power-Lift™ Hydraulic Fill Head Adjustment features a 48" travel range, allowing for ergonomic bag connections, adaptability to different bag sizes, and compensation for bag elongation.
- 4. Get Consistent Filling Results:** The Compact Logix PLC with 10" color HMI reduces labor costs, improves safety and operational efficiency, and delivers consistent, high-quality filling results.

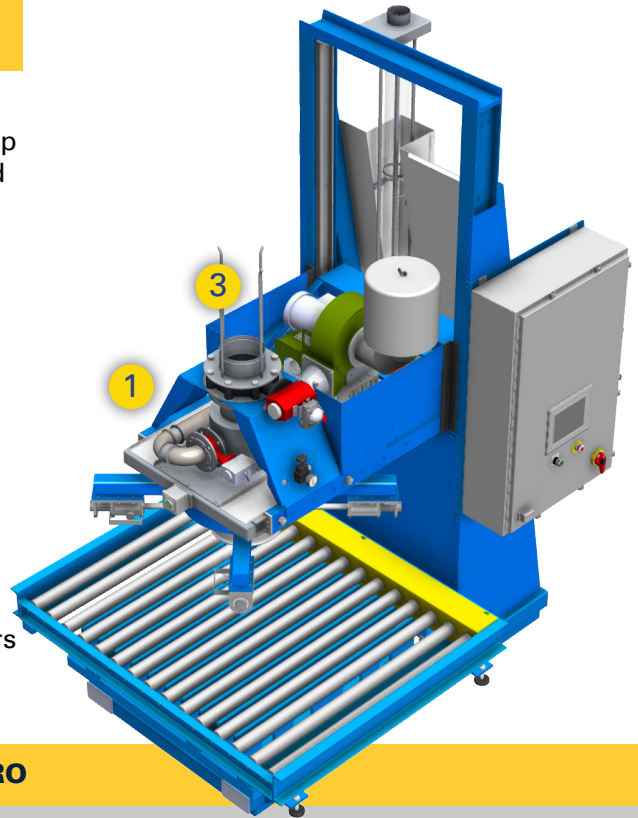

### AVAILABLE EXCLUSIVELY ON THE POWER-FILL® PRO

**Power-Trak™ Bag Support Carriage** Traversing bag support carriage extends 12" horizontally for reach-free, ergonomic bag spouting.

**Hang Weigh Scale** Bag is suspended from an isolated weighing assembly during filling for extremely accurate weight measurement..

# POWER-FILL® LIMITED

AN ECONOMICAL FILLER DESIGNED FOR LOW VOLUME FILLING APPLICATIONS

## STANDARD EQUIPMENT BENEFITS

- 1. Cleaner Operation:** Fill head with inflatable spout seal and dust vent port ensures dust-free performance.
- 2. Versatile Bag Support:** Adjustable strap hangers accommodate both square and rectangular bags.
- 3. Adaptable to Your Needs:** Manual frame height adjustment accepts a wide range of bag sizes.

## POWER-FILL® LIMITED: UPGRADES

**Integrated Platform Scale** provides gain in weigh filling capabilities.

**Digital Weight Display** programmed for reliable, accurate gain in weigh filling.

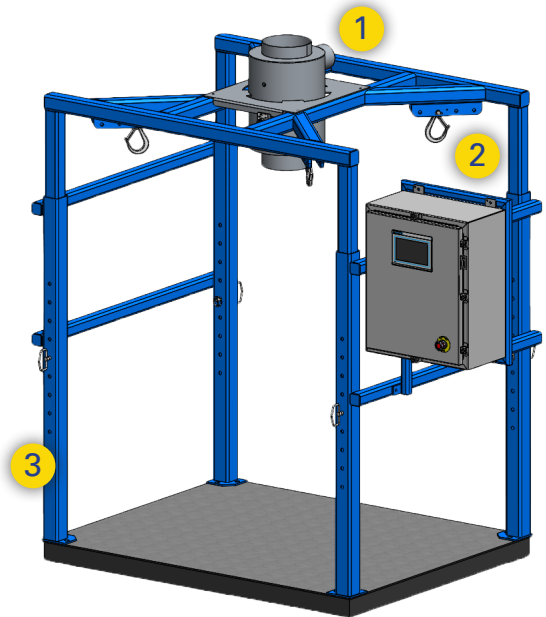

# POWER-FILL® SELECT

AN EXTREMELY CUSTOMIZABLE FILLER DESIGNED FOR MEDIUM VOLUME FILLING APPLICATIONS

## STANDARD EQUIPMENT BENEFITS

- 1. Effortless Height Adjustment:** Pneumatic Power-Lift™ ensures quick and precise fill head positioning—*available exclusively on the Power-Fill Select.*
- 2. Safe and Stable Filling:** Pallet support deck securely holds the pallet and bulk bag throughout the filling process.
- 3. Dust-Free Filling:** Inflatable spout seal ensures a secure connection to the bag, maintaining a clean operation.

## POWER-FILL® SELECT: UPGRADES

**Loop-Lok™ Powered Bag Strap Release** Safe and secure bag loop support with automatic release.

**Easy-Load™ Rotary Bag Hanger** The bag hanger rotates around a center axis for reliable reach-free bag loop connection.

**Fill By Weight** With load cells added to the base of the frame, configure for gain in weight filling and automation

**Pneumatic Bag Inflation with Valve** shapes bag prior to filling for maximum fill volume and stability.

**PLC/HM** Reduced labor cost with consistent filling results.

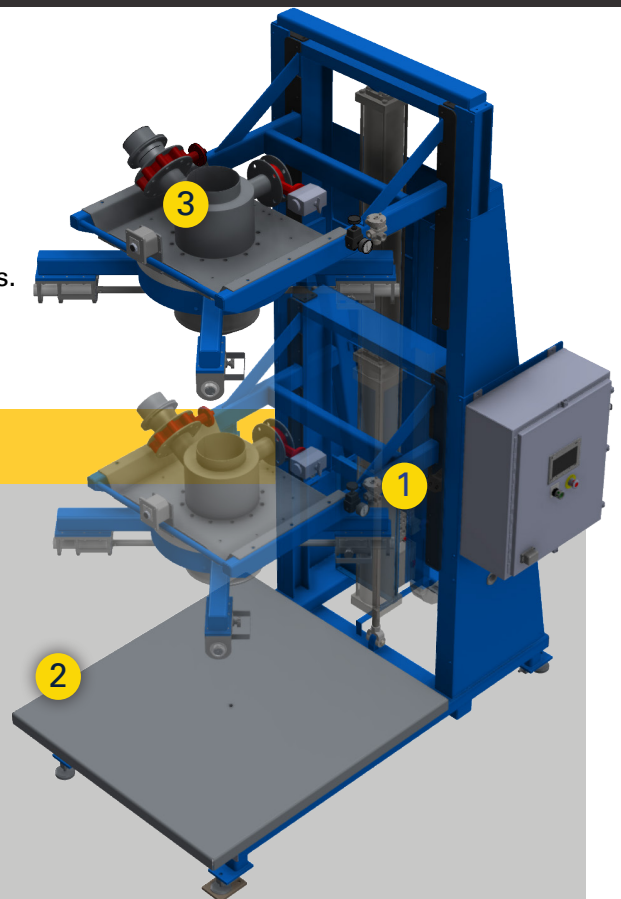

# CONTACT OUR CUSTOMIZATION EXPERTS TO LEARN HOW WE CAN TRANSFORM YOUR OPERATIONS!

OPTIONS & FEATURES	POWER-FILL® PRO	POWER-FILL® SELECT	POWER-FILL® LIMITED
Bag inflation system, pneumatic or electric	Optional	Optional	Optional
Clean-in-place system	Optional	Optional	Optional
Densification system	Optional	Optional	Optional
Dust take off on fill head with stub, no valve	Optional	<b>Standard</b>	Optional
Dust take off on fill head with actuated valve	<b>Standard</b>	Optional	Optional
Easy-Load™ rotary bag hanger	<b>Standard</b>	Optional	N/A
Fill by volume	Optional	Optional	Optional
Fill by weight, load cells beneath frame	<b>Standard</b>	Optional	Optional
Fill by weigh, hang weight	Optional	N/A	N/A
Fill head with inflatable spout seal	<b>Standard</b>	<b>Standard</b>	<b>Standard</b>
Fill valve with VPC, shipped loose	Optional	Optional	Optional
Gravity roller conveyor in filler base	Optional	Optional	Optional
Inlet isolation valve at filler inlet	Optional	Optional	Optional
Manual bag loop attach/release	N/A	<b>Standard</b>	<b>Standard</b>
PLC (A/B Micro with 7" color HMI)	N/A	Optional	Optional
PLC (A/B Compact Logix with 10" color HMI)	<b>Standard</b>	N/A	N/A
Pallet support deck	<b>Standard</b>	<b>Standard</b>	N/A
Portable base	Optional	Optional	Optional
Powered bag strap release (Loop-Lok™ system)	<b>Standard</b>	Optional	N/A
Powered filler base conveyor	Optional	Optional	Optional
Power-Lift™ pneumatic height adjustment	N/A	<b>Standard</b>	N/A
Power-Lift™ hydraulic height adjustment	<b>Standard</b>	N/A	N/A
Power-Trak™ traversing bag support carriage	Optional	N/A	N/A
Shrouding package	<b>Standard</b>	N/A	N/A
Additional pallet conveyor sections	Optional	Optional	Optional
Container or drum filling adaptors	Optional	Optional	Optional
Pallet or slip sheet dispensers	Optional	Optional	Optional

Material Transfer is an industry leader in the custom design and manufacture of bulk bag, container and drum filling, conditioning and discharging systems for dry powders and bulk solids. Building products robust in design, elegant in operation, simple to use and easy to maintain, you can count on Material Transfer for all your material handling needs.

## Explore Full System Options & Integrations

Our custom bulk material handling systems can be integrated to provide a complete solution built to outperform in your unique manufacturing environment.



Filling | Discharging | Loss/Gain In Weight Batching | Mechanical & Pneumatic Conveying | Storage | Feeding

**DRIVEN BY EXCELLENCE.**

269.673.2125 | MATERIALTRANSFER.COM

